

JVC

SERVICE MANUAL

CASSETTE RECEIVER

KS-FX270

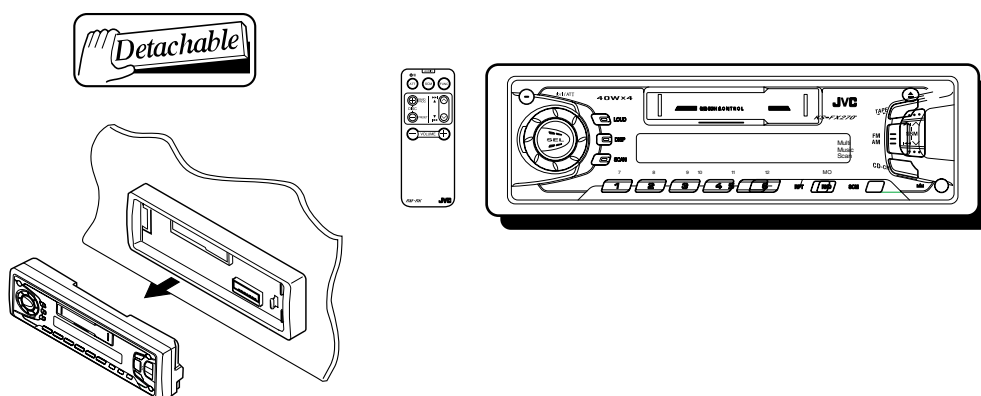

Area Suffix

J ---- Northern America

Contents

Safety precaution	1-2
Disassembly method	1-3
Adjustment method	1-12
Description of major ICs	1-16

Safety precaution

 **CAUTION** Burrs formed during molding may be left over on some parts of the chassis. Therefore, pay attention to such burrs in the case of performing repair of this system.

Disassembly method

<Main body>

■ Removing the front panel assembly (See Fig.1)

1. Press the eject button in the lower right part of the front panel. Remove the front panel assembly from the body.

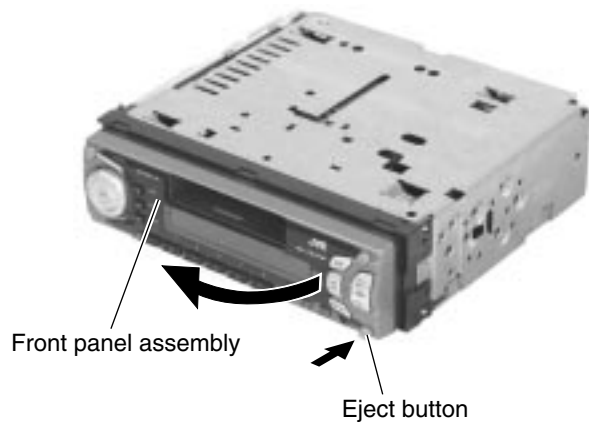

Fig.1

■ Removing the front chassis assembly (See Fig.2 and 3)

- Prior to performing the following procedure, remove the front panel assembly.

1. Release the four joint tabs **a** on both sides of the front chassis assembly and remove the front chassis assembly toward the front.

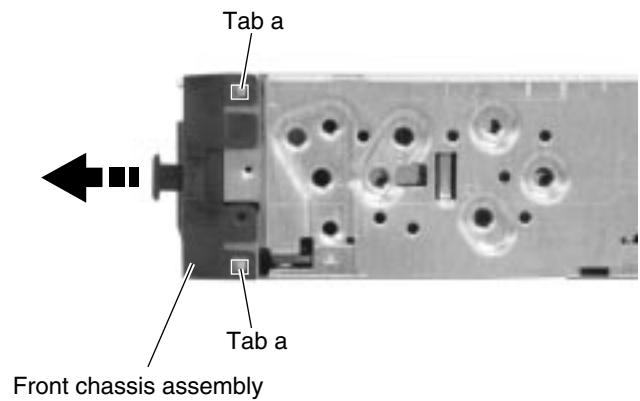

Fig.2

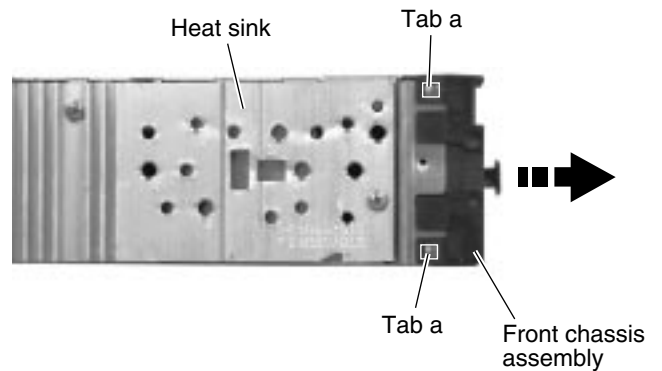

Fig.3

■ **Removing the heat sink (See Fig.4)**

1. Remove the three screws **A** on the left side of the body.

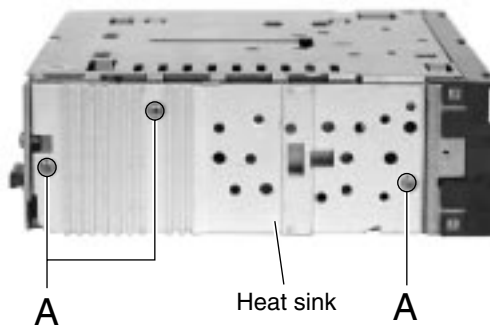

Fig.4

■ **Removing the bottom cover (See Fig.5 and 6)**

- Prior to performing the following procedure, remove the front panel assembly, the front chassis assembly and the heat sink.

1. Turn over the body and unjoint the five joints **b** with the bottom cover and the body using a screwdriver.

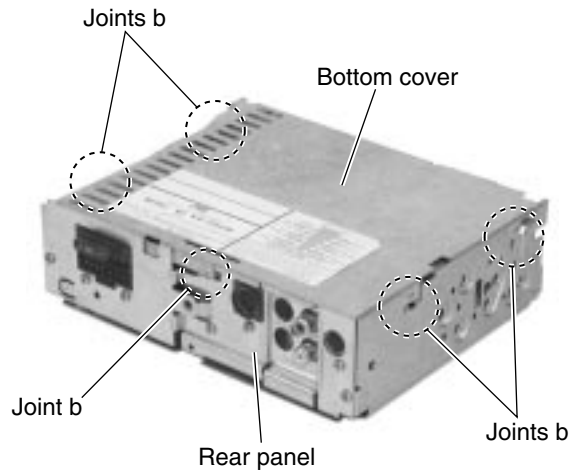

Fig.5

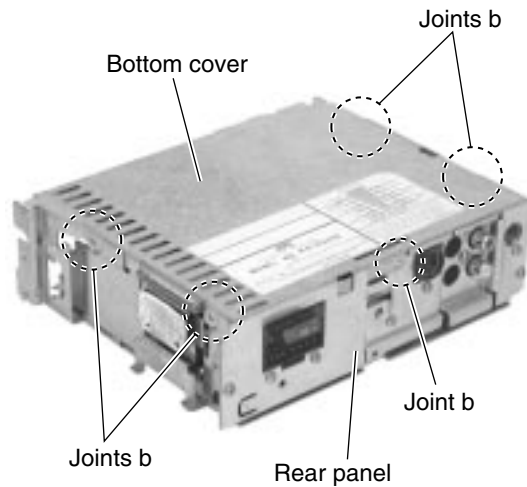

Fig.6

■ Removing the main board (See Fig.7 and 8)

• Prior to performing the following procedure, remove the front panel assembly, the front chassis assembly, the heat sink and the bottom cover.

1. Remove the screw **B**, the four screws **C** and the two screws **D** attaching the rear bracket on the back of the body. Remove the rear panel.
2. Remove the two screws **E** attaching the main board on the bottom of the body. Disconnect connector CN701 on the main board in the direction of the arrow.

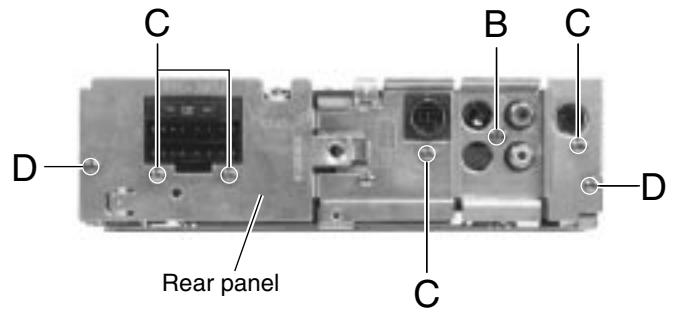

Fig.7

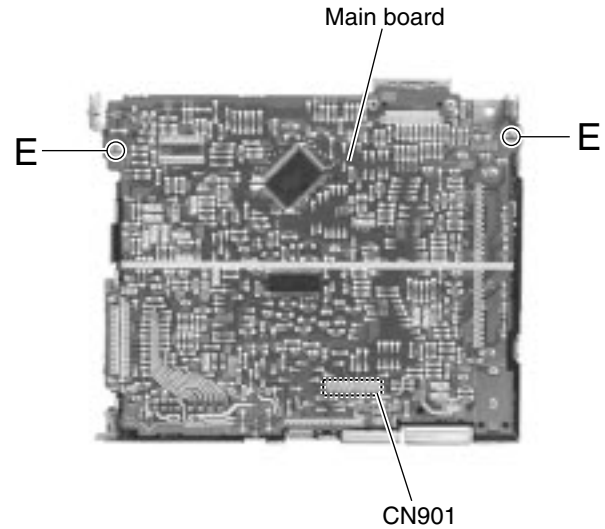

Fig.8

■ Removing the cassette mechanism section (See Fig.9)

• Prior to performing the following procedure, remove the front panel assembly, the front chassis assembly, the heat sink, the bottom cover and the main board.

1. Remove the four screws **F** attaching the cassette mechanism section on the back of the top chassis.

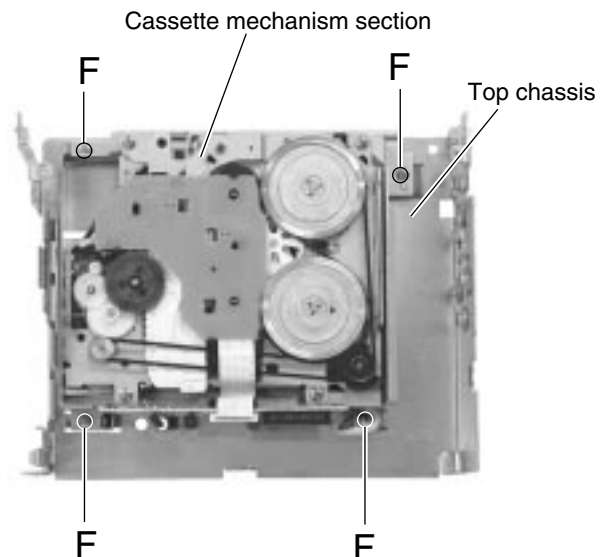

Fig.9

■ **Removing the control switch board**
(See Fig.10 to 12)

• Prior to performing the following procedure, remove the front panel assembly.

1. Remove the four screws **G** attaching the rear cover on the back of the front panel assembly.
2. Unjoint the six joints **c** with the front panel and the rear cover.
3. Remove the control switch board on the back of the front panel.

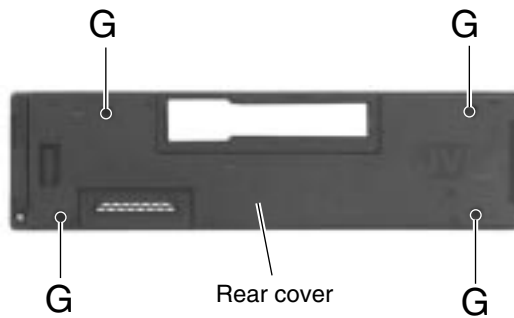

Fig.10

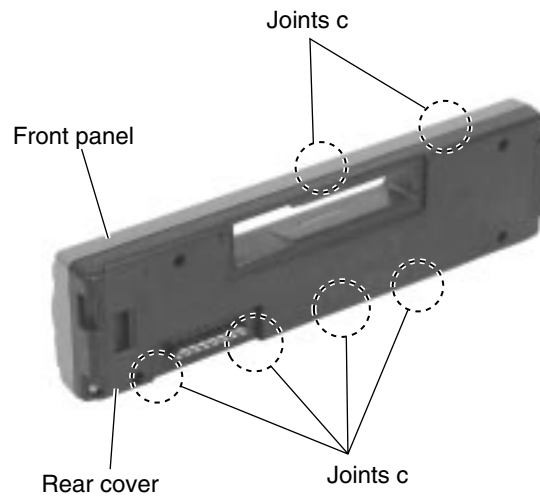

Fig.11

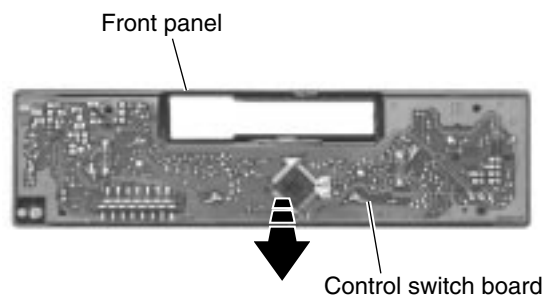

Fig.12

<Removal of the cassette mechanism>

■ Removing the head amplifier P.W.B. (See Fig.1 and 2)

1. For the 6pin harness extending from connector CN402 on the head amplifier P.W.B, disconnect it from the head relay P.W.B.
2. Disconnect the card wire from connector CN403 on the head amplifier P.W.B.
3. Remove the screw A attaching the head amplifier P.W.B.
4. Move the tab a as shown in Fig.2 and remove the head amplifier P.W.B. while moving it in the direction of the arrow.

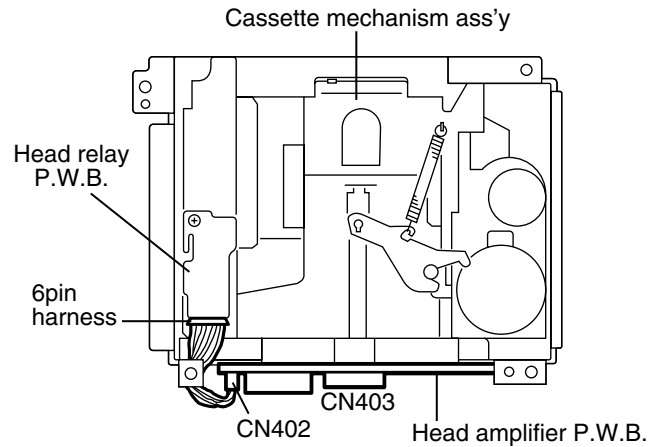

Fig.1

■ Removing the cassette mechanism assembly (See Fig.1 to 3)

1. Disconnect the 6pin harness from connector CN402 and the card wire from CN403 on the head amplifier P.W.B. (Refer to Fig.1 and 2).
2. Remove the four screws B on the bottom of the cassette mechanism.

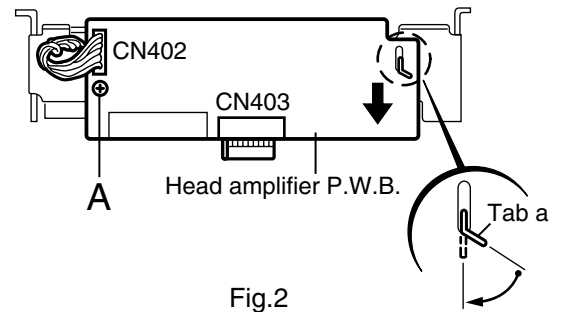

Fig.2

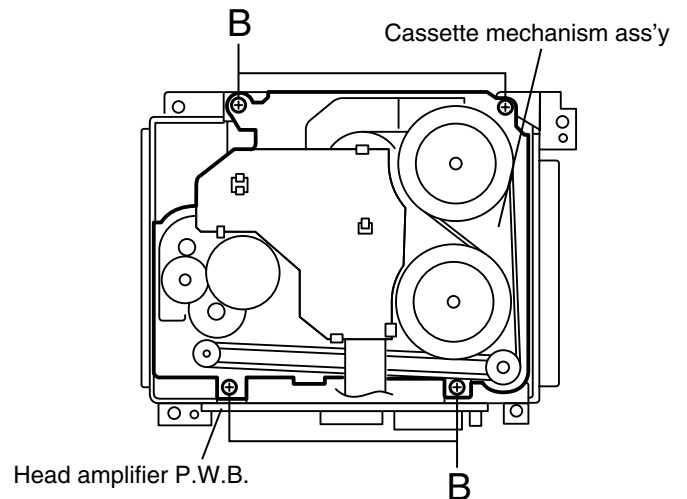

Fig.3

■ Removing the head relay P.W.B.
(See Fig.4)

1. Unsolder the soldering b on the head relay P.W.B.
2. Remove the screw C attaching the head relay P.W.B.
3. Remove the head relay P.W.B. in the direction of the arrow while releasing the two joints c.

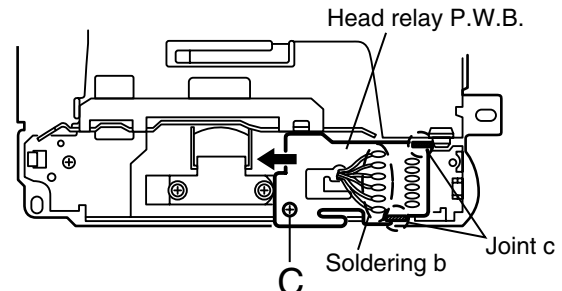

Fig.4

■ Removing the load arm (See Fig.5)

1. Remove the E washer attaching the load arm using a pincette or something like that and remove the spring d.
2. Move the part of the load arm marked ✕ upwards to release it from the axis of rotation. Then rotate the load arm in the direction of the arrow to remove it from the cach.

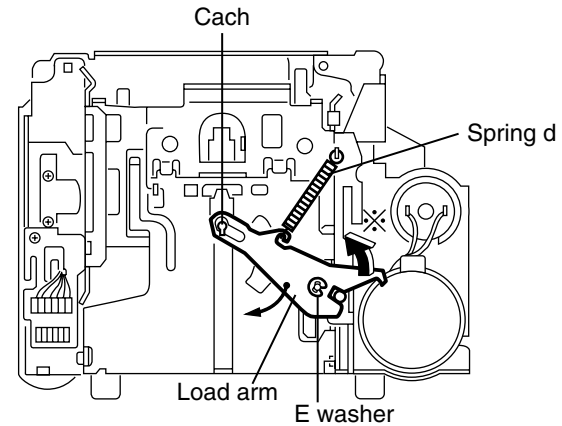

Fig.5

■ Removing the sub chassis (See Fig.6)

• Prior to performing the following procedure, remove the head relay P.W.B.

1. Remove the screw D attaching the sub chassis.
2. Push the tab e in the direction of the arrow to detach the one side of the sub chassis. Then release the sub chassis from the tab f.

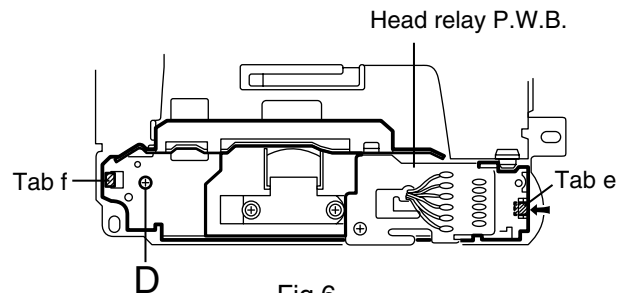

Fig.6

■ Removing the cassette holder and the holder arm in the eject mode
(See Fig.7 and 8)

• Prior to performing the following procedure, remove the head relay P.W.B., the load arm and the sub chassis.

1. Remove the screw E attaching the reinforce bracket.
2. Remove the reinforce bracket.
3. Push the tab g fixing the cassette holder in the direction of the arrow and open the cassette holder and the holder arm upward until they stop at an angle of 45 degrees. Move the two joints h to the side and remove the cassette holder and the holder arm from the shaft.

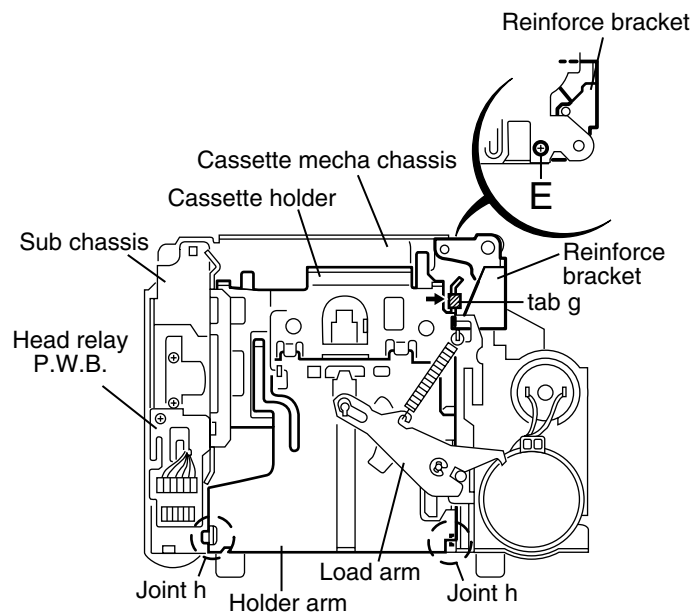

Fig.7

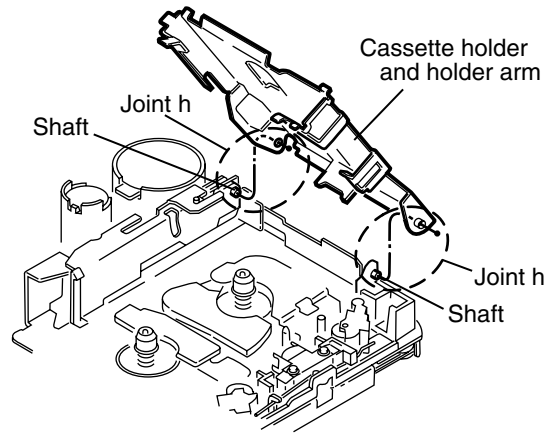

Fig.8

■ Removing the play head (See Fig.9)

• Prior to performing the following procedure, remove the head relay P.W.B.and the sub chassis.

1. Remove the two screws F attaching the play head (The spring under the play head comes off at the same time).

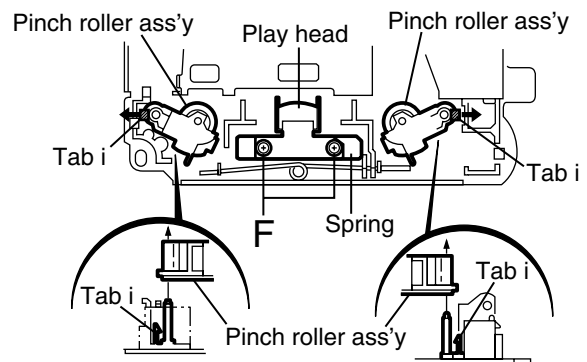

Fig.9

■ Removing the pinch roller ass'y (See Fig.9)

• Prior to performing the following procedure, remove the head relay P.W.B.and the sub chassis.

1. Push each tab i in the direction of the arrow and pull out the pinch rollers on both sides.

■ Removing the reel disc P.W.B. (See Fig.10)

1. Unsolder the soldering j on the reel disc P.W.B.
2. Push the seven tabs k on the bottom of the cassette mechanism assembly in the direction of the arrow.

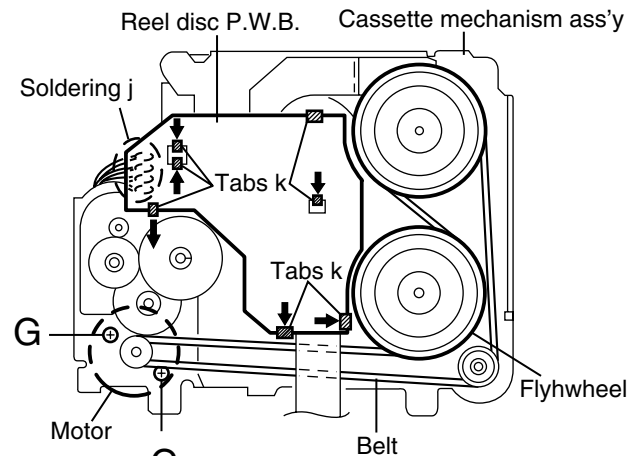

Fig.10

■ Removing the motor and the sub motor (See Fig.10 and 11)

1. Unsolder the two soldering l of the motor and the sub motor.
2. Release the sub motor from the three tabs m. Push the sub motor upward and pull out it.
3. Remove the belt on the bottom of the cassette mechanism assembly and remove the two screws G attaching the motor.

ATTENTION: The motors can be detached before removing the load arm.

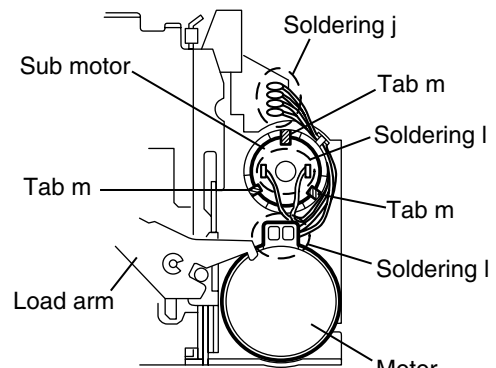

Fig.11

■ Removing the flywheel

(See Fig.10 and 12)

1. Prior to performing the following procedure, remove the head relay P.W.B, the load arm, the sub chassis, the cassette holder, the holder arm and the reel disc P.W.B.
2. Remove the belt on the bottom of the cassette mechanism ass'y.
3. Remove the slit washer attaching the flywheel on the upper side of the cassette mechanism ass'y and pull out the flywheel downward. Then remove another flywheel in the same way.

ATTENTION: When reassembling, make sure to use a new slit washer.

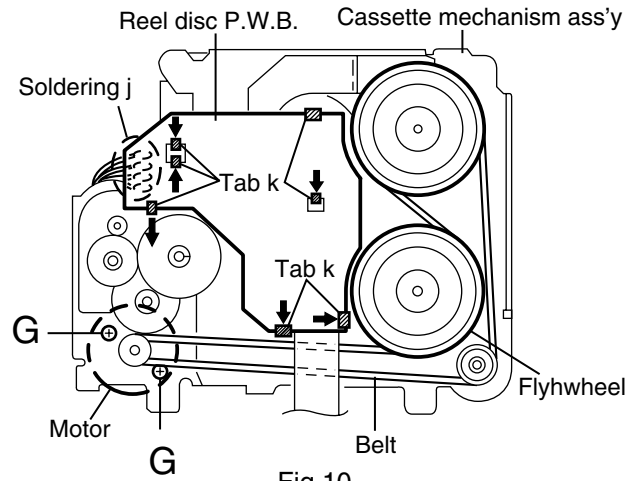

Fig.10

■ Removing the reel disc ass'y (I)

(See Fig.12 to 14)

- Prior to performing the following procedure, remove the head relay P.W.B, the load arm, the sub chassis, the cassette holder and the holder arm.
1. Disengage the part n inside of the reel driver which engages with the shaft, using a pincette or something like that. Then remove the reel driver from the shaft.
 2. Remove the reel driver spring and the reel table.

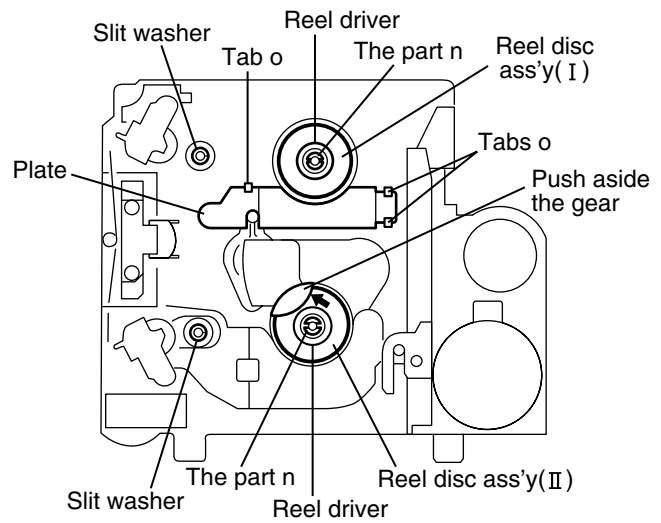

Fig.12

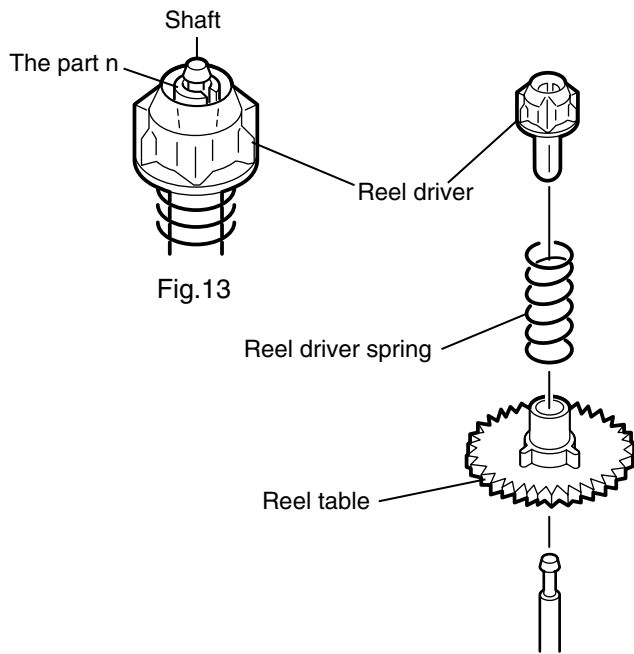

Fig.13

Fig.14

■ **Removing the reel disc ass'y(Ⅱ)**
(See Fig.12 to 15)

ATTENTION: Prior to performing the following procedure, remove the reel disc (I).

1. Release the plate from the three tabs o.
2. Push aside the gear over the reel table using a pincette or something like that.
3. Remove the reel disc ass'y (Ⅱ) as with the reel disc ass'y (I).

ATTENTION: Do not break the front panel tab fitted to the metal cover.

Push aside the gear and reattach the reel disc Ass'y(I).

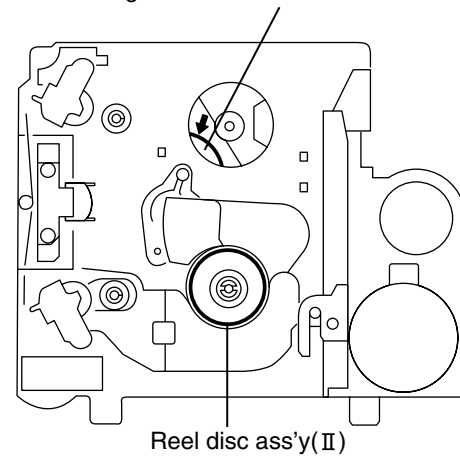

Fig.15

Adjustment method

■ Test instruments required for adjustment

1. Digital oscilloscope(100MHz)
2. Frequency Counter meter
3. Electric voltmeter
4. Wow & flutter meter
5. Test Tapes
 - MC-109C for TAPA CURL confirmation
(without Padd type)
 - VT724 for DOLBY level measurement
 - VT739 For playback frequency measurement
 - VT712 For wow flutter & tape speed measurement
 - VT703 For head azimuth measurement
6. Torque gauge Cassette type for CTG-N
(mechanism adjustment)

■ Measuring conditions(Amplifier section)

- Power supply voltage DC14.4V (10.5 - 16V)
- Load impedance 4 (2Speakers connection)
- Line out 20k

■ Standard volume position

Balance and Bass, Treble volume .Fader
:Center(Indication"0")
Loudness, Dolby NR, Sound, Cruise:Off
Volume position is about 2V at speaker output with
following conditions. Playback the test tape VT721.

- AM mode 1000kHz/62dB, INT/400Hz, 30%
 modulation signal on receiving.
- FM mono mode 97.5MHz/66dB, INT/400Hz, 22.5kHz
 deviation pilot off mono
- FM stereo mode 1kHz, 67.5kHz dev. pilot 7.5kHz dev.
- Output level 0dB(1 V, 50 /open terminal)

■ Arrangement of adjusting & test points

Cassette mechanism
(Surface)

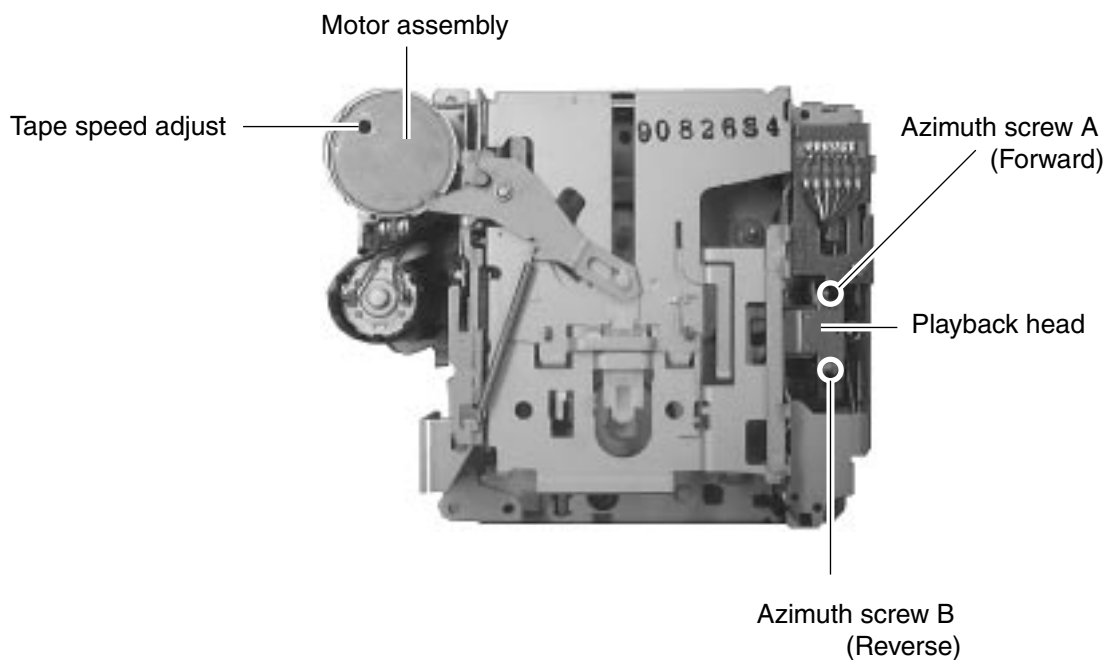

Head section view

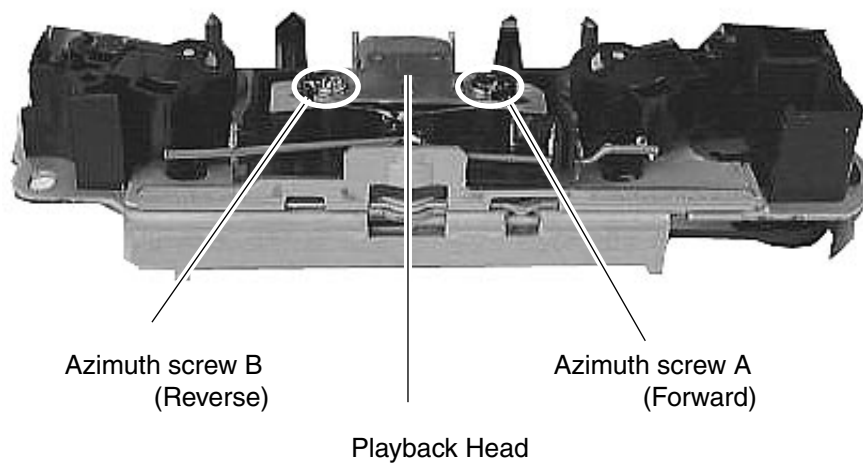

■ **Information for using a car audio service jig**

1. We're advancing efforts to make our extension cords common for all car audio products.
Please use this type of extension cord as follows.
2. As a U-shape type top cover is employed, this type of extension cord is needed to check operation of the mechanism assembly after disassembly.
3. Extension cord : EXTKSRT002-18P (18 pin extension cord) For connection between mechanism assembly and main board assembly.
Check for mechanism driving section such as motor ,etc..

■ **Disassembly method**

1. Remove the bottom cover.
2. Remove the front panel assembly.
3. Remove the top cover .
4. Install the front panel.
5. Confirm that current is being carried by connecting an extension cord jig.

Note

Available to connect to the CP701 connector when installing the front panel.

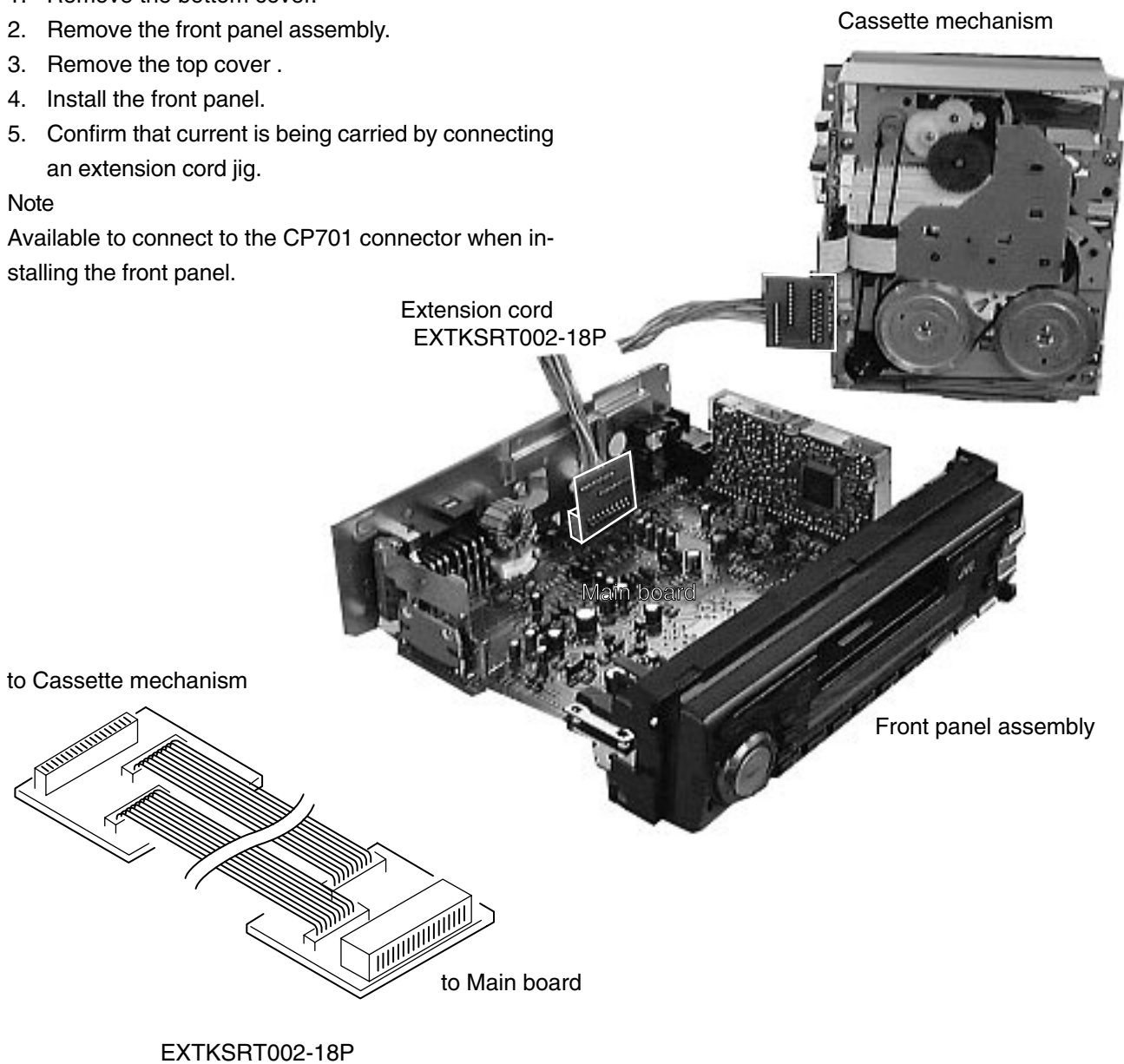

■ Mechanism adjustment section

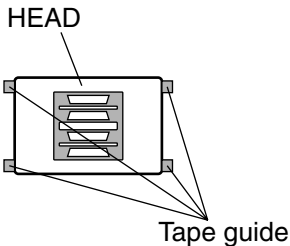
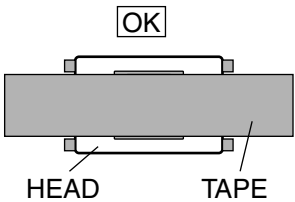
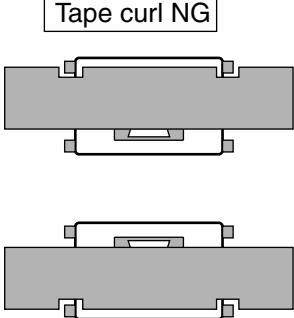
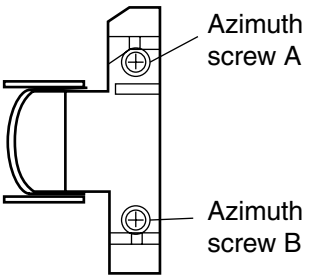
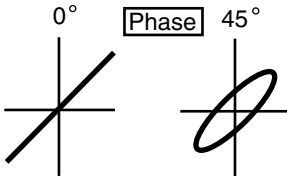
Item	Adjusting & Confirmation Methods	Adjust Std. Value	
<p>1. Tape running adjustment</p> <p>2. Azimuth adjustment confirmation</p>	<p>a) At Forward playmode, using mirror tape, make adjustment with Azimuth screw A and Azimuth screw B, without curl of 4 parts of head tape guide.</p> <p>b) At Reverse play mode, using mirror tape, make adjustment with Azimuth screw A and Azimuth screw B, without tape curl of 4 parts of head tape guide.</p> <p>c) At Forward / Reverse play mode, make confirmation of no tape curl of 4 parts of head tape guide.</p> <p>a) At forward play mode, make adjustment of peak of Lch / Rch output with Azimuth screw A. * For Oscilloscope litharge corrugation, set 45° as standard.</p> <p>b) At Reverse play mode, make adjustment of peak of Lch / Rch output with Azimuth screw B. * For Oscilloscope litharge corrugation, set 45° as standard.</p> <p>c) With AC volt meter confirm the difference of output for 4ch between Lch / Rch at forward play mode and Lch / Rch Reverse play mode being within 3.0dB.</p> <p>d) After operation, make confirmation of Lch / Rch azimuth output being within 1.0dB from adjustment value.</p> <div style="text-align: center;">  </div> <div style="display: flex; justify-content: space-around; margin-top: 20px;"> <div style="text-align: center;">  <p>OK</p> </div> <div style="text-align: center;">  <p>Tape curl NG</p> </div> </div>	<div style="text-align: right;">  </div> <div style="text-align: center; margin-top: 20px;">  </div>	
<p>2. Tape Speed and Wow & Flutter</p>	<p>1. Check to see if the reading of the frequency counter & Wow flutter meter is within 2940-3090 Hz(FWD/REV), and less than 0.35% (JIS RMS).</p> <p>2. In case of out of specification, adjust the motor with a built-in volume resistor .</p>	<p>Built-in volume resistor</p>	<p>Tape Speed 2940-3090Hz Wow&Flutter Less than 0.35% (JIS RMS)</p>
<p>3. Playback Frequency response</p>	<p>1. Play the test tape (VT724 : 1kHz) back and set the volume position at 2V .</p> <p>2. Play the test tape (VT739)back and confirm 0±3dB at 1kHz/ 10kHz and -4+2dB at 1kHz/63Hz.</p> <p>3. When 10kHz is out of specification, it will be necessary to read adjust the azimuth.</p>		<p>Speaker out 1kHz/10kHz : 0dB±3dB, 63Hz/1kHz : -4dB+2dB,</p>

Description of major ICs

TEA6320T-X (IC161) : E.volume

1.Pin layout

SDA	1	32	SCL
GND	2	31	VCC
OUTLR	3	30	OUTRR
OUTLF	4	29	OUTRF
TL	5	28	TR
B2L	6	27	B2R
B1L	7	26	B1R
IVL	8	25	IVR
ILL	9	24	ILR
QSL	10	23	QSR
IDL	11	22	IDR
MUTE	12	21	Vref
ICL	13	20	ICR
IMD	14	19	CAP
IBL	15	18	IBR
IAL	16	17	IAR

2.Block diagram

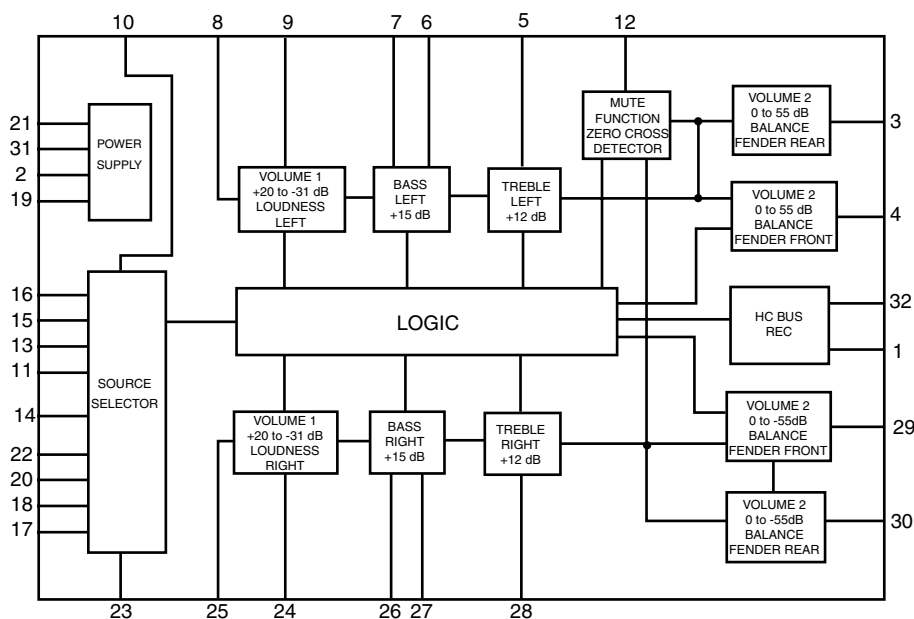

3.Pin functions

Pin No.	Symbol	I/O	Functions	Pin No.	Symbol	I/O	Functions
1	SDA	I/O	Serial data input/output.	17	IAR	I	Input A right source.
2	GND	-	Ground.	18	IBR	I	Input B right source.
3	OUTLR	O	output left rear.	19	CAP	-	Electronic filtering for supply.
4	OUTLF	O	output left front.	20	ICR	I	Input C right source.
5	TL	I	Treble control capacitor left channel or input from an external equalizer.	21	Vref	-	Reference voltage (0.5Vcc)
6	B2L	-	Bass control capacitor left channel or output to an external equalizer.	22	IDR	-	Not used
7	B1L	-	Bass control capacitor left channel.	23	QSR	O	Output source selector right channel.
8	IVL	I	Input volume 1. left control part.	24	ILR	I	Input loudness right channel.
9	ILL	I	Input loudness. left control part.	25	IVR	I	Input volume 1. right control part.
10	QSL	O	Output source selector. left channel.	26	B1R	-	Bass control capacitor right channel
11	IDL	-	Not used	27	B2R	O	Bass control capacitor right channel or output to an external equalizer.
12	MUTE	-	Not used	28	TR	I	Treble control capacitor right channel or input from an external equalizer.
13	ICL	I	Input C left source.	29	OUTRF	O	Output right front.
14	IMO	-	Not used	30	OUTRR	O	Output right rear.
15	IBL	I	Input B left source.	31	Vcc	-	Supply voltage.
16	IAL	I	Input A left source.	32	SCL	I	Serial clock input.

■ AN80T05LF (IC901) : Regulator

1. Terminal layout & Block diagram

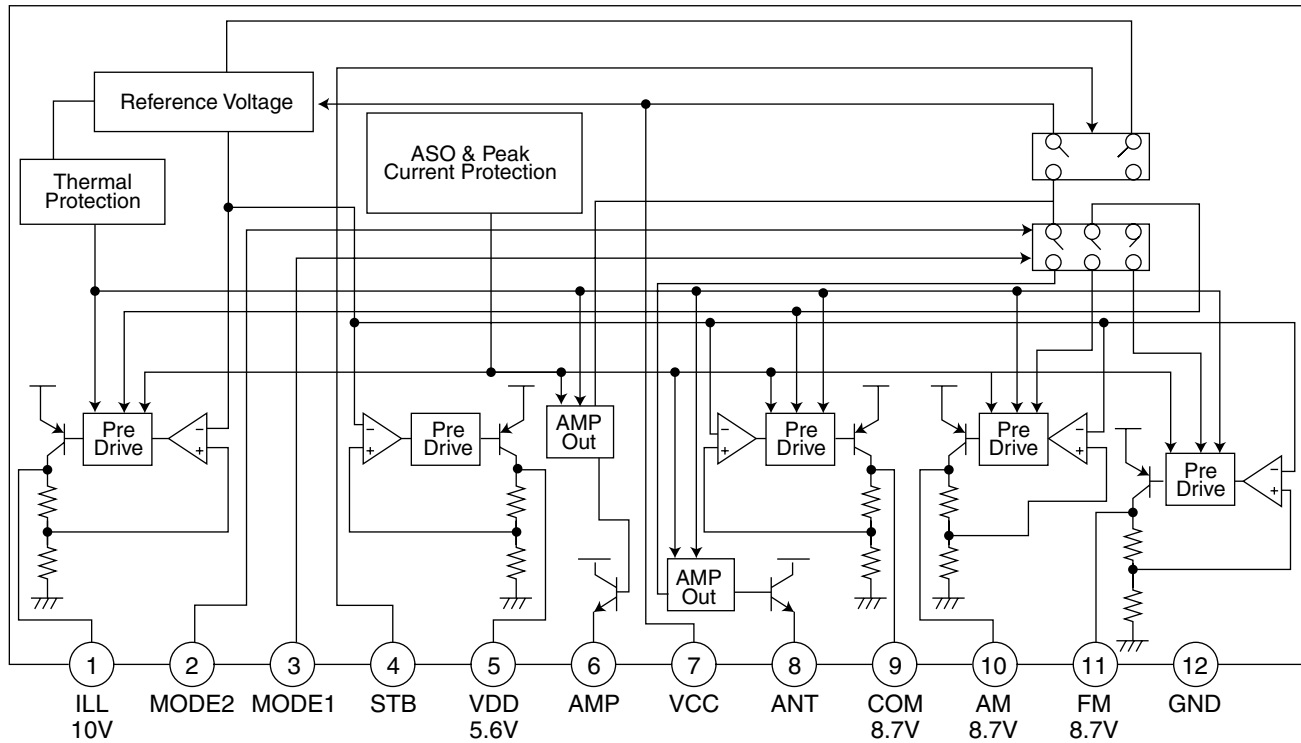

2. Pin function

Pin No.	Symbol	Function
1	ILL	10V power supply for illumination.
2	MODE2	When 5V is input, becomes AM. and the antenna output is turned on.
3	MODE1	When 5V is input, becomes AM. and the output of FM is switched.
4	STB	When 5V is input, outputs to ILL, COM, and AMP. It is 0V usually.
5	VDD	5.6V power supply.
6	AMP	Power supply supply to remote amplifier
7	VCC	Back up. connects with ACC with it.
8	ANT	Power supply supply to auto antenna.
9	COM	8.7V power supply.
10	AM	The power supply of 8.7V to AM.
11	FM	The power supply of 8.7V to FM.
12	GND	Ground

■ CXA2559Q(IC401):Head amp.

1.Pin layout

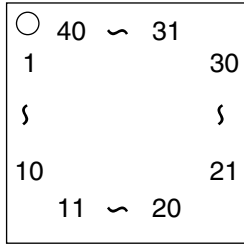

2.Blockdiagram

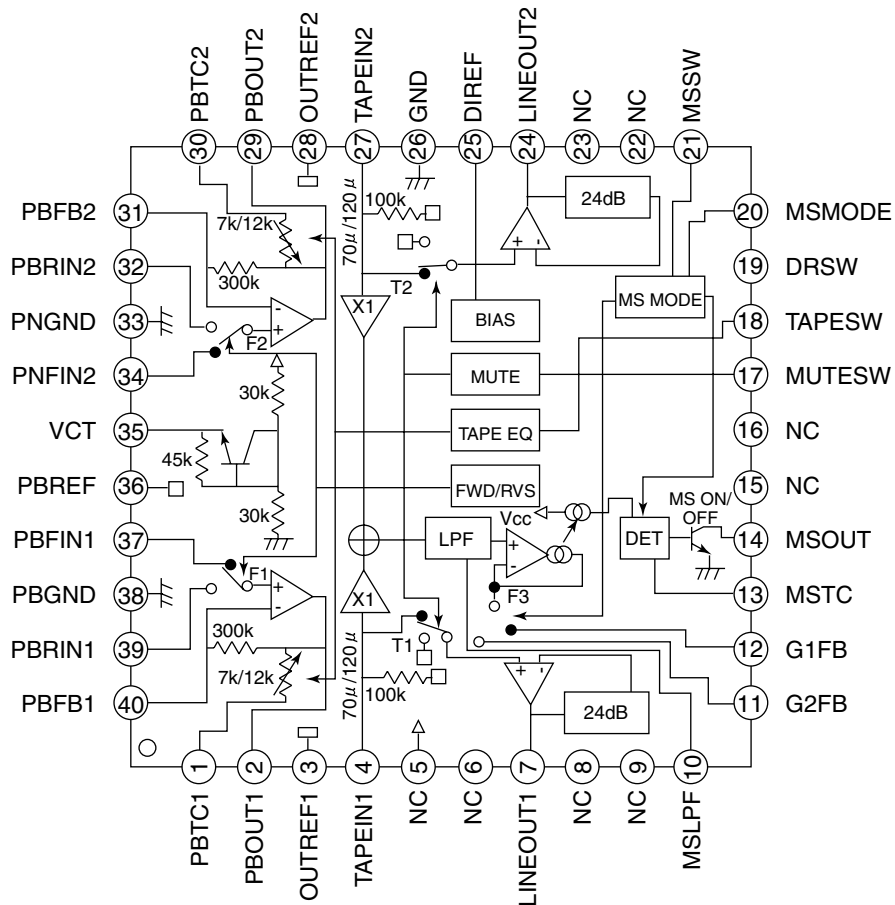

3.Pin function

CXA2559Q 2/2

Pin No.	Symbol	I/O	Function
1	PBTC1	-	Terminal of capacity of reproduction equalizer reproduction
2	PBOUT1	O	Equalizer output terminal
3	OUTREF1	O	Output standard terminal
4	TAPEIN1	I	Tape input terminal
5	Vcc	-	Power supply terminal
6	NC	-	Non connection
7	LINEOUT1	O	Line-out output terminal
8	NC	-	Non connection
9	NC	-	Non connection
10	MSLPF	-	Detection LPF terminal between tunes
11	G2FB	-	Detection level set terminal between tunes
12	G1FB	-	Detection level set terminal between tunes
13	MSTC	-	Time constant connection terminal for the detection between tunes
14	MSOUT	O	Detection output terminal between tunes
15	NC	-	Non connection
16	NC	-	Non connection
17	MUTESW	I	Mute function control terminal
18	TAPESW	I	Reproduction equalizer control terminal
19	DRSW	I	Head change control terminal
20	MSMODE	I	Detection mode control terminal between tunes
21	MSSW	I	Detection function control terminal between tunes
22	NC	-	Non connection
23	NC	-	Non connection
24	LINEOUT2	O	Line-out output terminal
25	DIREF	-	Resistance connection terminal for standard current setting
26	GND	-	Earth terminal
27	TAPEIN2	I	Tape input terminal
28	OUTREF2	O	Output standard terminal
29	PBOUT2	O	Reproduction equalizer output terminal
30	PBTC2	-	Terminal of capacity of reproduction equalizer
31	PBFB2	I	Reproduction equalizer return terminal
32	PNRIN2	I	Reproduction equalizer input terminal
33	PBGND	-	Reproduction equalizer system earth terminal
34	PBFIN2	I	Reproduction equalizer input terminal
35	VCT	O	Middle point terminal
36	PBREF	O	Reproduction equalizer standard terminal
37	PBFIN1	I	Reproduction equalizer input terminal
38	PBGND	-	Reproduction equalizer system earth terminal
39	PBRIN1	I	Reproduction equalizer input terminal
40	PBFB1	I	Reproduction equalizer return terminal

■ LC72366-9985 (IC701) : SYSTEM CPU

1. Pin layout

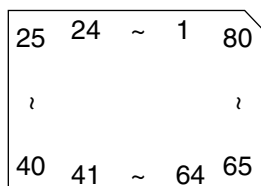

2. Pin function

Pin No.	Symbol	I/O	Function
1	XIN	I	Crystal oscillator input port
2	GND	-	Connect to GND
3	J-BUS SI	I	Data input for J-BUS information
4	J-BUS SO	O	Data output for J-BUS information
5	J-BUS SCK	O	Clock output for J-BUS information
6	J-BUS I/O	O	Switching signal output for J-BUS information I/O, H:Out L:In
7	NC	-	None connection
8	LCD SO	O	Data output for LCD driver
9	LCD SCK	O	Information clock output for LCD driver data
10	LCD CE	O	Chip enable output for LCD driver
11	DIMMER IN	-	None connection
12	EVOL SO	O	Data output for electrical volume
13	EVOL SCK	O	Clock output for electrical volume information
14	NC	-	Non connection
15	TUNER ILLUM	-	Non connection
16	TAPE ILLUM	-	Non connection
17	CD ILLUM	-	Non connection
18	DEMERIT	-	Non connection
19	NC	-	Non connection
20	OPEN	-	Non connection
21	NC	-	Non connection
22	NC	-	Non connection
23	NC	-	Non connection
24	NC	-	Non connection
25	KS1	-	Non connection
26	KS0	O	Diode matrix output port for initial establishing
27	K3	I	Diode matrix output port for initial establishing
28	K2	I	Diode matrix output port for initial establishing
29	K1	-	Non connection
30	K0	I	Diode matrix output port for initial establishing
31	Vdd	-	5V power supply port (+B)
32	TEST	I	Turn on all light indicator of LCD, L: All light a LED indicator
33	FF/REW MODE	O	FF/REW mode select signal output
34	SEEK/STOP	O	H:Auto seek, L: Stop Use both as IF count REQ and Seek/Stop
35	MONO	O	Forced monaural output port, H:Turn on Forced monaural
36	RADIO/TAPE	-	Non connection
37	BEEP LEVEL	-	Non connection
38	PWR-CNT	O	"H" : Turn on power
39	ACC	-	Non connection
40	KICK	-	Non connection

Pin No.	Port Name	I/O	Function
41	MOTOR	O	Main motor output, H:Transport L: Stop
42	SUBMO+	O	Sub-motor output(+), Loading direction to transport output
43	SUBMO-	O	Sub-motor output(-), Eject direction to transport output
44	BEEP	-	Non connection
45	TAPE IN	I	Switch for detecting to input cassette, L: Cassette in
46	STANDBY	I	Switch for detecting standby position
47	REEL	I	Switch for detecting tape end position
48	MODE	I	Detecting mode position input
49	F/R	I	Switch for detecting forward/reverse , H:FWD L:REV
50	MS	I	MS input port,
51	SD/ST	I	Station detector, Stereo signal input, H:SD
52	DETACH	O	Front panel detect
53	ENC1	I	Connect to encoder 1
54	ENC2	I	Connect to encoder 2
55	J-BUS INT	I	Cut in signal detecting port from J-Bus information
56	REMOCON	-	Non connection
57	FM/AM	O	FM/AM mode switching signal port, H:FM L:AM
58	DOLBY	-	Non connection
59	NC	-	Non connection
60	MUTE	O	Mute output port, L:Mute
61	MEM DET	I	Back-up power supply detecting port, H:input L:no input
62	LEVELMETER	I	Pressure voice level voltage input for level meter.
63	S.METER	I	S meter voltage input
64	KEY2	I	Key 2 input port
65	KEY1	I	Key 1 input port
66	KEY0	I	Key 0 input port
67	ACCDET	I	Hold port for Acc detecting, L: Hold mode
68	SENSE	I	Voltage sensor port
69	AM IF COUNT	-	Non connection
70	FM IF COUNT	I	FM frequency detecting
71	NC	-	Non connection
72	NC	-	Non connection
73	Vdd	-	5V power supply (+B)
74	AM OSC	I	Non connection
75	FM OSC	I	FM limited signal input
76	VSS	-	Ground port for power supply
77	NC	-	Non connection
78	E0	O	Error signal output port for PLL
79	TEST1	-	Test port for LSI, To connect ground
80	XOUT	O	4.5MHz crystal oscillator output

■ HA13158A (IC301) : Power amp

1. Pin layout

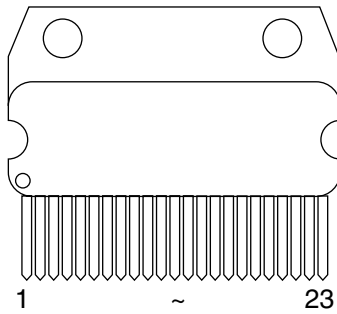

2. Block diagram

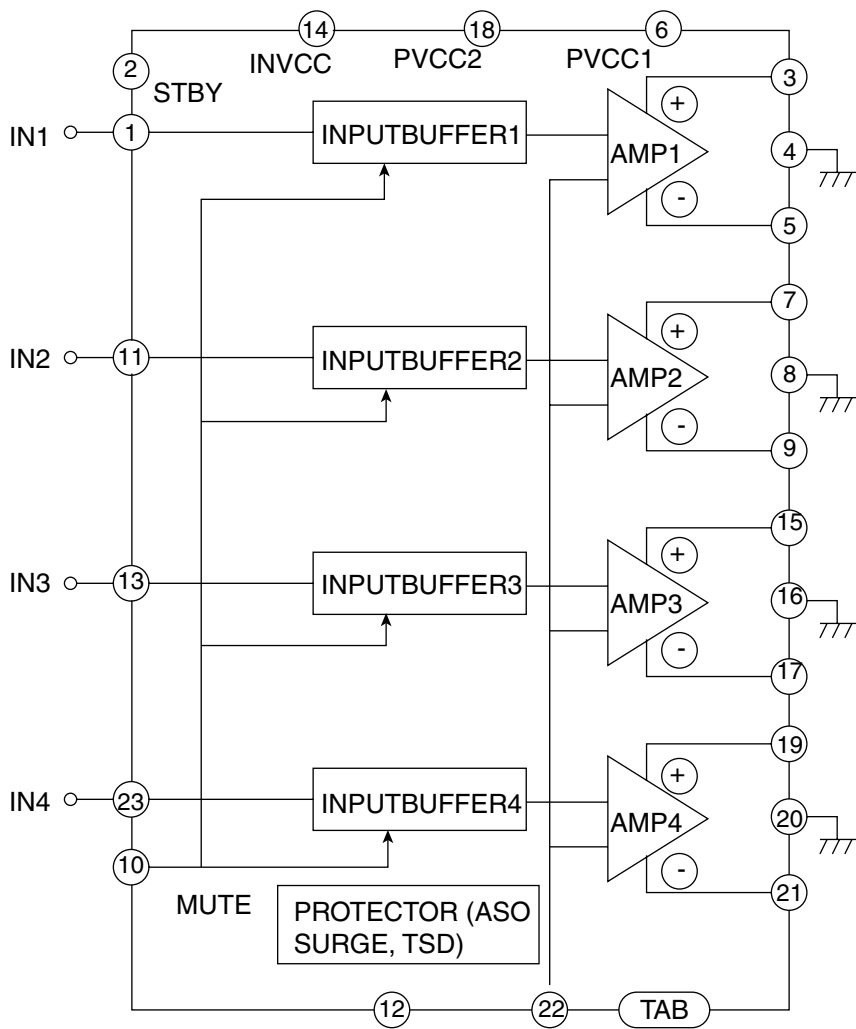

■ LC75823W (IC651) : LCD driver

1. Pin Layout & Symbol

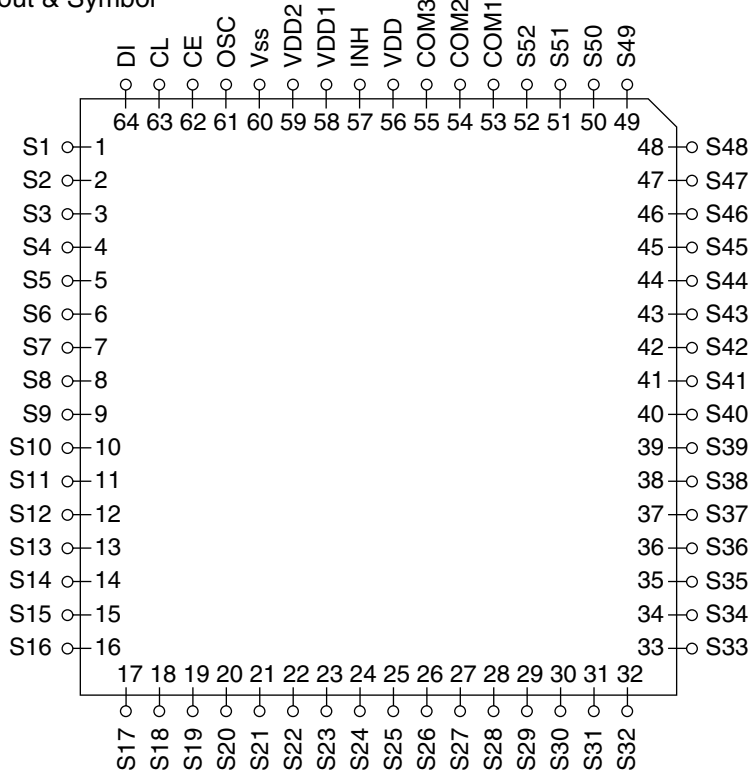

2. Pin Function

Pin No.	Symbol	I/O	Function
1 to 52	S1 to S52	O	Segment output pins used to display data transferred by serial data input.
53 to 55	COM1 to COM3	O	Common driver output pins. The frame frequency is given by : $t_0=(f_{osc}/384)Hz$.
56	VDD	--	Power supply connection. Provide a voltage of between 4.5 and 6.0V.
57	\overline{INH}	I	Display turning off input pin. $\overline{INT}="L"$ (Vss) ----- off (S1 to S52, COM1 to COM3="L" $\overline{INT}="H"$ (VDD)----- on Serial data can be transferred in display off mode.
58	VDDD1	I	Used for applying the LCD drive 2/3 bias voltage externally. Must be connected to VDD2 when a 1/2 bias drive scheme is used.
59	VDD2	I	Used for applying the LCD drive 1/3 bias voltage externally. Must be connected to VDD1 when a 1/2 bias drive scheme is used.
60	Vss	--	Power supply connection. Connect to GND.
61	OSC	I/O	Oscillator connection. An oscillator circuit is formed by connecting an external resistor and capacitor at this pin.
62	CE		Serial data interface connection CE : Chip enable
63	CL	I	to the controller. CL : Sync clock
64	DI		DI : Transfer data

■ KIA7810PI (IC902) : Regulator

1.Pin layout

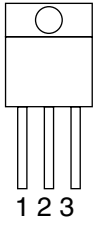

2.Block diagram

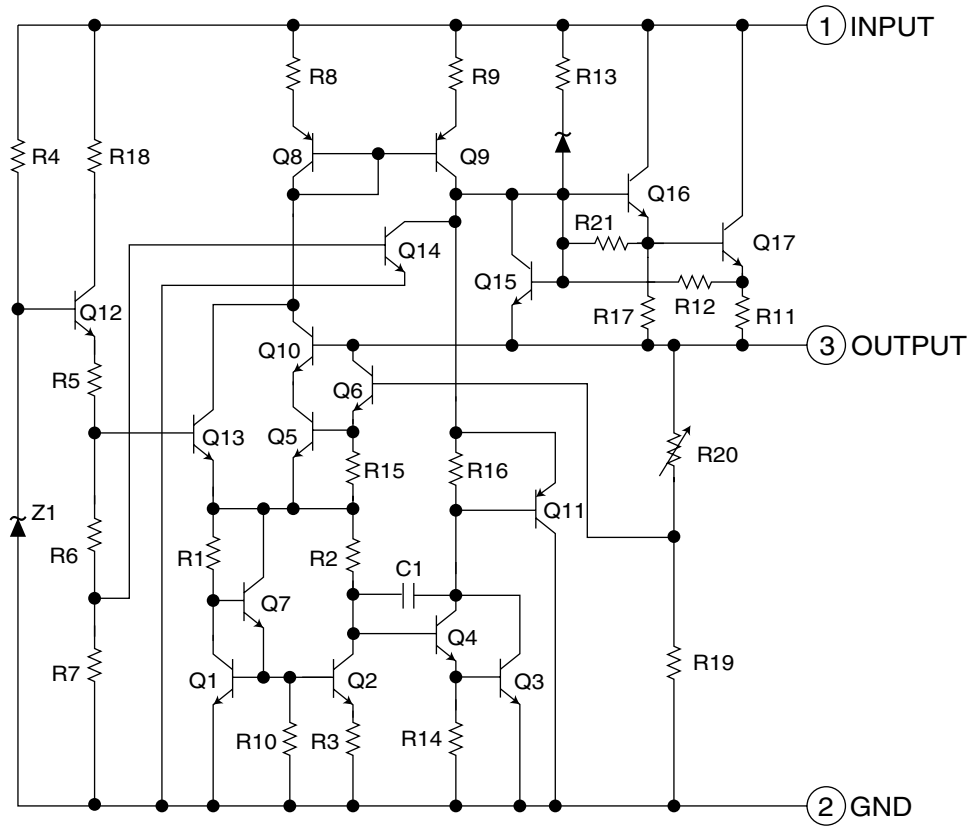

■ LB1641 (IC402) : DC motor driver

1. Pin layout

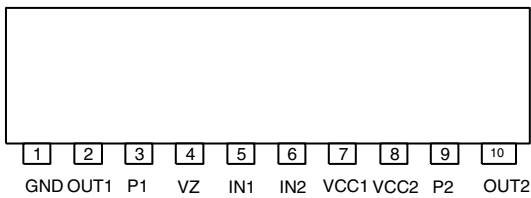

2. Pin function

Input		Output		Mode
IN1	IN2	OUT1	OUT2	
0	0	0	0	Brake
1	0	1	0	CLOCKWISE
0	1	0	1	COUNTER-CLOCKWISE
1	1	0	0	Brake

■ RPM6938-SV4(IC652) : Remote Censor

1. Block diagram

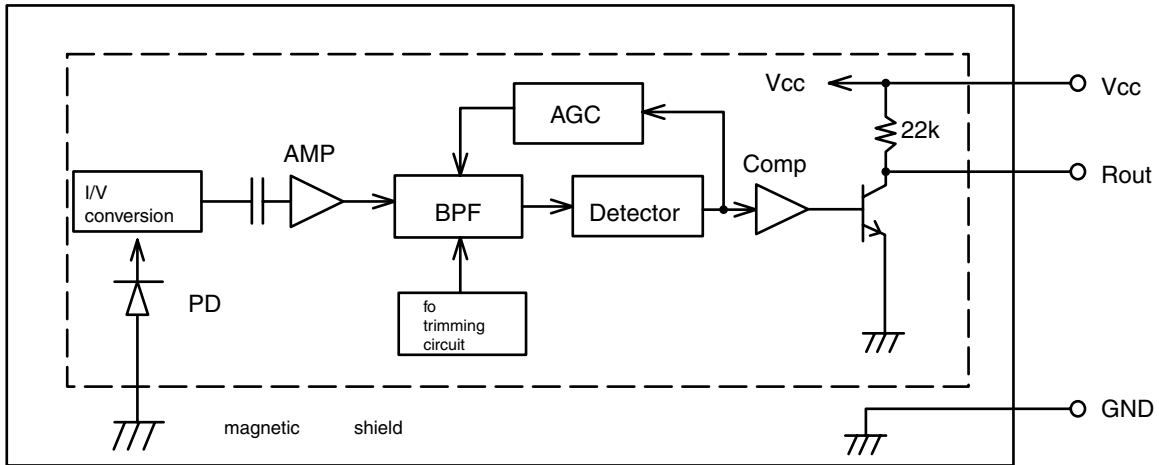

■ HD74HC126P (IC801) : Bus buffer

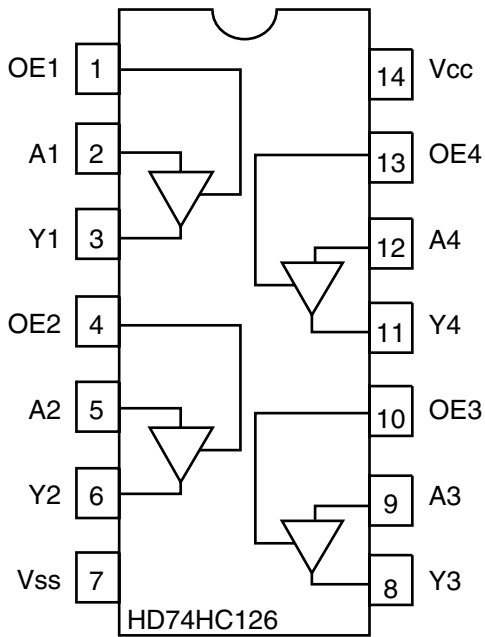



VICTOR COMPANY OF JAPAN, LIMITED
MOBILE ELECTRONICS DIVISION
PERSONAL & MOBILE NETWORK BUSINESS UNIT. 10-1,1Chome,Ohwatari-machi,Maebashi-city,Japan